

## Product Features

- Sensitive and rapid action
- Small volume and light weight
- Easy regulation and maintenance
- Excellent and reliable sealing performance
- Built-in strainer, to prevent the guide piping system from being blocked
- Optional check feature

SL300 solenoid control valve mainly controls opening and closing of the valve by receiving the opening or closing signal through the solenoid valve. It consists of a basic valve and an electromagnetic switch. The electromagnetic switch controls the liquid in the air chamber to achieve the purpose of controlling the valve to open and to close.

The standard opening and closing speed control valve can independently control the opening and closing speeds of the valve to avoid the water hammer and vibration common in solenoid valves.

If the optional check feature is selected, when the back pressure is generated, the return fluid will enter the air chamber to close the valve to prevent the fluid from back flow.

### Material Specifications

**Body/Bonnet:** Ductile Iron/Stainless Steel  
**Disc & Stem:** Stainless Steel  
**Piping:** Bronze/Stainless Steel/Rubber Hose  
**Diaphragm:** EPDM  
**Fasteners and Springs:** Stainless Steel

### Working Pressure Range

175PSI/235PSI  
 10Bar/16Bar

### Flange Standards

ANSI / BSEN / ISO / DIN

### Temperature/Medium

0°C~100°C normal temperature water

### Solenoid Valve Parameters

**Voltage Range:** 110 V, 50-60 Hz, AC or 220 V, 50-60 Hz

**State:** NC (normally closed) or NO (normally open) (please specify the specific state while ordering)

**Body Material:** Brass/Stainless steel

### Please Provide the Following Data When Ordering

Valve figure number/size/pressure grade/connecting end type/voltage range/NC or NO/other optional accessories

\* Note: In valve installation, it is strongly suggested that sufficient space should be left for easy maintenance in the future. A strainer shall be mounted in front of the valve to prevent foreign matters from blocking the valve.

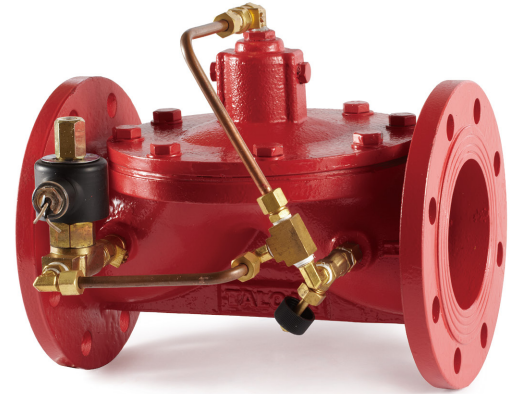

SL300

### List of Accessories

- ① Strainer (Built-In)
- ② Ball Valve
- ③ Needle Type Regulating Valve
- ④ Ball Valve
- ⑤ Electromagnetic Switch
- ⑥ Ball Valve
- ⑦ Body

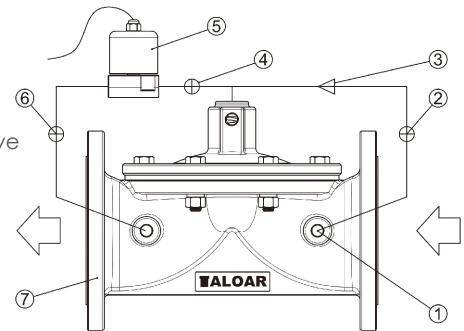

Piping Diagram

### Typical Applications

SL300 solenoid control valve is applicable to many situations in the industry, such as mixing, cleaning, stirring and other occasions that require switching control.

The switching signal can direct control signal or the signal generated by the sensor to control the valve to open and to close. The solenoid control valve can be used to control water level. The sensor installed on the water storage tank generates the switching signal to control the opening and closing of solenoid control valve, so as to control water level.

